

Typical Feature

- ◆ Fixed Input Voltage, isolated & unregulated dual Output, power 1W
- ◆ Operating Temperature: -40°C to +105°C
- ◆ Small SMD package, international standard pin out
- ◆ Isolation Voltage 3000VDC
- ◆ High efficiency up to 86%
- ◆ Low no load input current



Application Filed

NN1-XXDXXA3NT is suitable for pure digital systems, low frequency analog circuits, relay-driven circuits. It is specially designed for applications where an isolated voltage is required in a distributed power supply system.

It could be widely used in the below products:

1. The voltage of the input power supply is relatively stable(voltage change range:±10%Vin)
2. Isolation between input and output is required (Isolation Voltage≤3000VDC);
3. Low requirements for output voltage stability and output ripple noise;

Typical Product List

Part No	Input Voltage	Output Voltage/Current		Input Current(mA)		Max. Capacitive Load	Ripple & Noise 20MHz (TYP/MAX)	Efficiency (MIN/TYP)
	(VDC)	Voltage	Current	Nominal Voltage				
	Range	(VDC)	(mA) MAX / MIN	Full load typ.	No load typ.	u F	mVp-p	%
NN1-05D05A3NT	5 (4.5-5.5)	±5	±100/±10	230	8	1200	80/100	81/84
NN1-05D09A3NT		±9	±55/±6	228	10	1200	80/100	81/84
NN1-05D12A3NT		±12	±42/±4	226	14	470	80/100	81/84
NN1-12D05A3NT	12 (10.8-13.2)	±5	±100/±10	98	8	1200	80/100	81/84
NN1-12D12A3NT		±12	±42/±4	96	8	470	80/100	82/85
NN1-12D15A3NT		±15	±33/±3	92	9	470	80/100	83/86
NN1-24D05A3NT	24 (21.6-26.4)	±5	±100/±10	48	8	1200	80/100	81/84

Note 1: The typical output efficiency is based on that product is full loaded and burned-in after half an hour.

Note 2: The fluctuation range of full load efficiency(% ,TYP) is ±3%, full load output efficiency= total output power/module's input power.

Note 3: Ripple & Noise Tested by twisted-pair method, for details please check Ripple& Noise Test Method.

Input Specifications

Item	Operating Condition	Min.	Typ.	Max.	Unit
Reflected Ripple Current	-	-	15	-	mA
Overshoot Voltage	5Vdc Input	-0.7	-	9	VDC
	12Vdc Input	-0.7	-	18	
	24Vdc Input	-0.7	-	30	
Input Filter Type	Capacitor Filter				

Hot Plug		Unavailable
----------	--	-------------

Output Specifications

Item	Operating Condition		Min.	Typ.	Max.	Unit
Output Voltage Accuracy	-		See Regulation Curve			
Line Regulation	Input voltage change ±1%	3.3Vdc/5Vdc Output	-	-	±2.0	%
		Other Output	-	-	±1.5	
Load Regulation	10%-100% load	3.3Vdc/5Vdc Output	-	10	15	%
		Other Output	-	8	10	
Temperature Drift Coefficient	Full load		-	-	±0.03	%/°C
Short Circuit Protection	Continuous, Self-recovery					

General Specifications

Item	Operating Condition	Min.	Typ.	Max.	Unit
Isolation Voltage	Input-output, Test 1min, leakage current≤0.5mA	3000	-	-	VDC
Insulation Resistance	Input-output, Insulation Voltage 500VDC	1000	-	-	MΩ
Isolation Capacitor	Input-output, 100KHz/0.1V	-	20	-	PF
Operating Temperature	Temperature≥105°C, see Temperature Derating Curve	-40	-	85	°C
Case Temperature Rise	Ambient Temperature 25°C	-	15	25	
Storage Temperature	-	-55	-	125	
Reflow Temperature	Peak temperature Tc≤245°C, for above 217°C max 60S				
Storage Humidity	No condensing	-	-	95	%RH
Switching Frequency	Full load, Input Standard Voltage	-	330	-	KHz
MTBF	MIL-HDBK-217F@25°C	3000			K hours

Material Characteristics

Case Material	Black flame-retardant heat-resistant plastic (UL94 V-0)				
Packing Dimension	SMD package	15.24X11.40X7.25 mm			
Product Weight		1.4g(TYP)			
Cooling Method	Natural air cooling				

EMC Character

EMI	CE	CISPR32/EN55032 CLASS B (See EMC recommended circuit)
	RE	CISPR32/EN55032 CLASS B (See EMC recommended circuit)

Packing Information

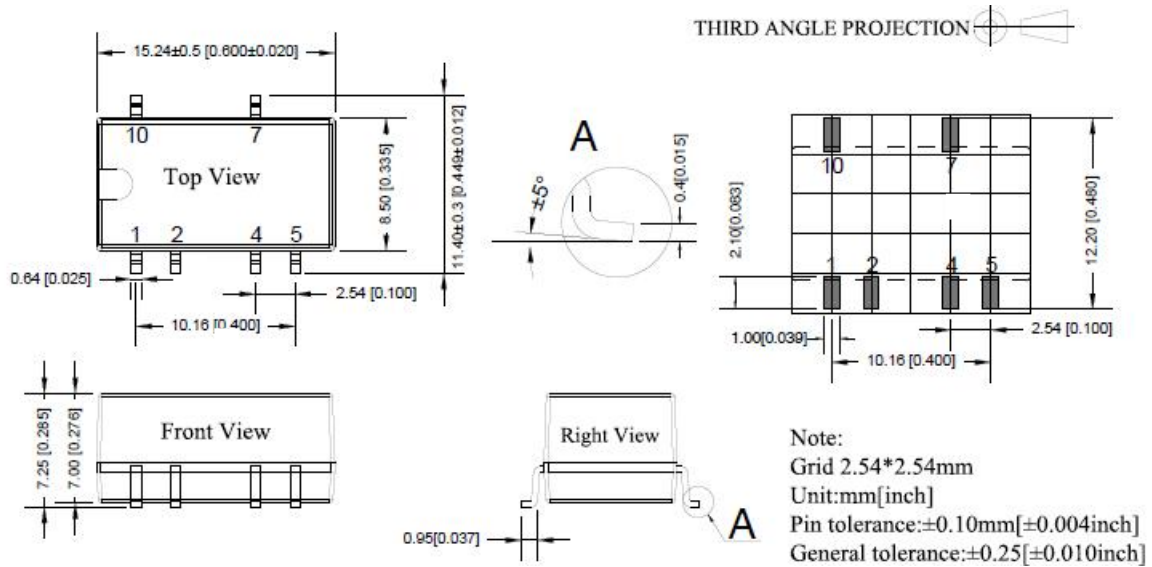

Pin Definition

Pin-Out	1	2	4	5	7	10
Function	GND	Vin	0V	-Vo	+Vo	*NC

*NC:cannot connected to any external circuit; pin specs:0.25*0.64; unit:mm

Ripple & Noise Test(Twisted Pair Method 20MHz bandwidth)

Test Method:

(1) 12# twisted pair to connect, Oscilloscope bandwidth set as 20MHz, 100M bandwidth probe, terminated with 0.1uF polypropylene capacitor and 4.7uF high frequency low resistance electrolytic capacitor in parallel, oscilloscope set as Sample pattern.

(2) Input terminal connect to power supply, output terminal connect to electronic load through jig plate, Use 30cm±2 cm sampling line, Power line selected from corresponding diameter wire with insulation according to the flow of output current.

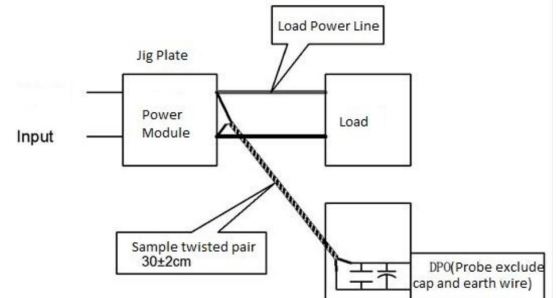

Output Voltage Regulation Curve

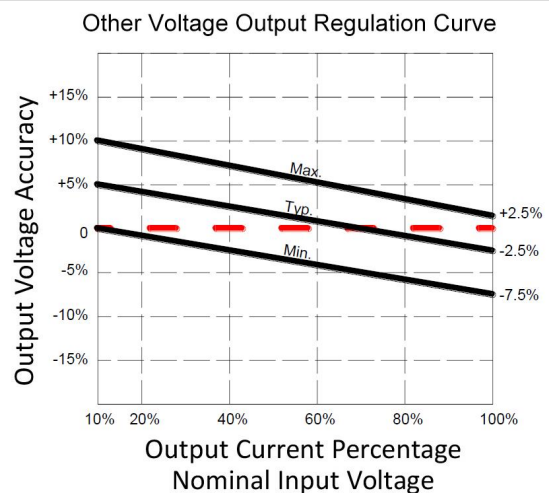
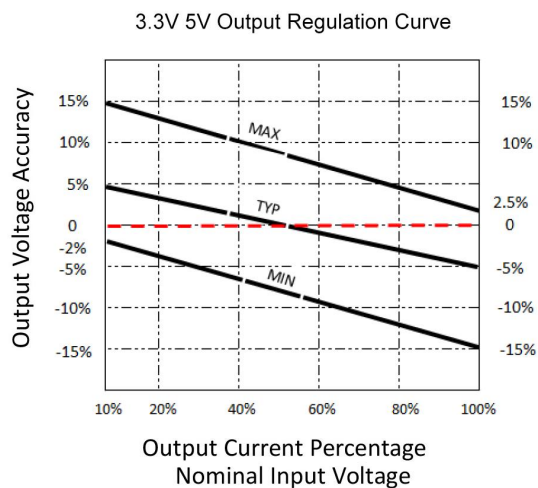

Products Characteristic Curve

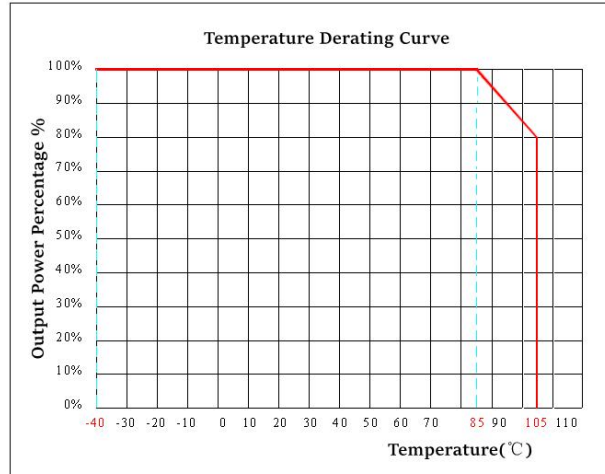

Application Circuit

1. Typical Application

In order to ensure the input/output ripple and noise decreased, capacitor filter net could be connected to input and output side, application circuit as below photo 3; choosing suitable filter capacitor is very important, start-up problems may be caused by too large capacitance.

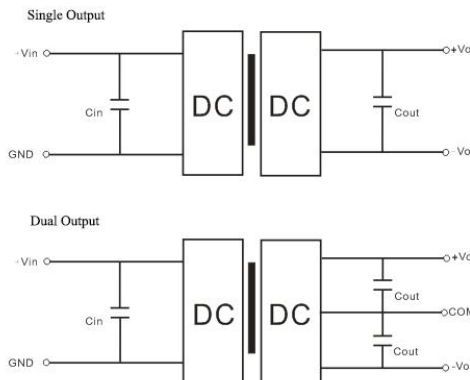

Recommended Capacitive Load (Table 1)

Vin (Vdc)	Cin	Single Vout Vdc	Cout (μF)	Dual Vout (Vdc)	Cout (μF)
5	10 μF/16V	3.3	10 μF/16V	±3.3	4.7 μF/16V
12	2.2 μF/25V	5	10 μF/16V	±5	4.7 μF/16V
15	2.2 μF/25V	9	2.2 μF/25V	±9	2.2 μF/25V
24	1 μF/50V	12	2.2 μF/25V	±12	1 μF/25V
--	--	15	1 μF/25V	±15	1 μF/16V
--	--	24	1 μF/50V	±24	0.47 μF/50V

2. EMC Typical Recommended Circuit

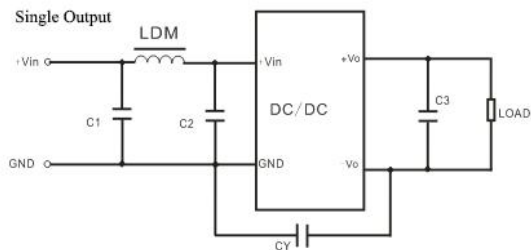

Input Voltage		5VDC	12/15/24VDC
EMI	C1/C2	4.7 μF/16V	4.7 μF/50V
	CY	270pF/2kV	270pF/2kV
	C3	Refer to Cout spec in table 1	Refer to Cout spec in table 1
	LDM	6.8 μH	6.8 μH

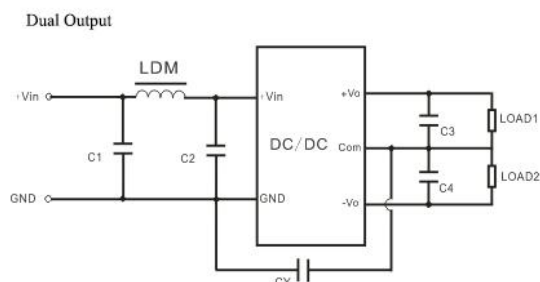

Input Voltage		5VDC	12/15/24VDC
EMI	C1/C2	4.7 μF/16V	4.7 μF/50V
	CY	270pF/3kVdc	270pF/3kVdc
	C3/C4	Refer to Cout spec in table 1	Refer to Cout spec in table 1
	LDM	6.8 μH	6.8 μH

3. Output Load Requirements

In order to ensure that the module can work efficiently and reliably, its output minimum load cannot be less than 10% of the rated load when in use. If the power you need is really small, please connect a resistors in parallel (the sum of the power consumed by the resistor and the actual power used is greater than or equal to 10% of the rated power).

Note:

1. The product should be used within the specification range, otherwise it will cause permanent damage to the product;
2. If the product works under the minimum required load, the product performance cannot be guaranteed to meet all the performance indicators in this manual;
3. If the product works beyond the load range of the product, the performance of the product cannot be guaranteed to meet all the performance indicators in this manual;
4. Unless otherwise specified, the above data are all measured at $T_a=25^{\circ}\text{C}$, humidity<75%, input nominal voltage and output rated load (pure resistance load);
5. The test methods of all the above indicators are based on the company's standards;
6. The above are the performance indicators of the product models listed in this manual. Some indicators of non-standard model products will exceed the above requirements. For details, please contact our technical personnel directly;
7. Our company can provide product customization;
8. Product specifications are subject to change without prior notice. Please pay attention to the latest manual published on our official website.

Guangzhou Aipu Electron Technology Co., Ltd

Address: Building 4, HEDY Park, No.63, Punan Road, Huangpu Dist, Guangzhou, China.

Tel: 86-20-84206763 Fax: 86-20-84206762 HOTLINE: 400-889-8821

E-mail: sales@aipu-elec.com Website: www.aipupower.com